

ICS 91.220

English version

Façade scaffolds made of prefabricated components - Part 1:
Products specifications

Echafaudages de façade à composants préfabriqués -
Partie 1: Spécifications des produits

Fassadengerüste aus vorgefertigten Bauteilen - Teil 1:
Produktfestlegungen

This European Standard was approved by CEN on 4 September 2003.

CEN members are bound to comply with the CEN/CENELEC Internal Regulations which stipulate the conditions for giving this European Standard the status of a national standard without any alteration. Up-to-date lists and bibliographical references concerning such national standards may be obtained on application to the Management Centre or to any CEN member.

This European Standard exists in three official versions (English, French, German). A version in any other language made by translation under the responsibility of a CEN member into its own language and notified to the Management Centre has the same status as the official versions.

CEN members are the national standards bodies of Austria, Belgium, Czech Republic, Denmark, Finland, France, Germany, Greece, Hungary, Iceland, Ireland, Italy, Luxembourg, Malta, Netherlands, Norway, Portugal, Slovakia, Spain, Sweden, Switzerland and United Kingdom.



EUROPEAN COMMITTEE FOR STANDARDIZATION
COMITÉ EUROPÉEN DE NORMALISATION
EUROPÄISCHES KOMITEE FÜR NORMUNG

Management Centre: rue de Stassart, 36 B-1050 Brussels

Contents

	Page
1 Scope	5
2 Normative references	5
3 Terms and definitions	6
4 Classification	6
5 Designation	7
6 Materials	7
7 General requirements	9
8 Requirements for structural design	12
9 Manuals	14
10 Marking	15
11 Assessment	15
Annex A (informative) Components commonly used in prefabricated scaffold systems	16
Annex B (informative) Typical bracing methods	18
Annex C (informative) Information about A-Deviations, selection of classes and administrative national regulations	19
Annex ZB (Informative) National A-Deviations	20

Foreword

This document (EN 12810-1:2003) has been prepared by Technical Committee CEN/TC 53 "Temporary works equipment", the secretariat of which is held by DIN.

This European Standard shall be given the status of a national standard, either by publication of an identical text or by endorsement, at the latest by June 2004, and conflicting national standards shall be withdrawn at the latest by June 2004.

This document also contains an informative annex ZB.

This European Standard supersedes the European Harmonisation document HD 1000:1988 "Service and working scaffolds made of prefabricated elements; Materials, dimensions, design loads and safety requirements".

This European Standard is one of a series of standards as listed below.

EN 12810-1, *Façade scaffolds made of prefabricated components — Part 1: Product specifications.*

EN 12810-2, *Façade scaffolds made of prefabricated components — Part 2: Particular methods of structural design.*

EN 12811-1, *Temporary works equipment — Part 1: Scaffolds — Performance requirements and general design.*

prEN 12811-2, *Temporary works equipment — Part 2: Information on materials.*

EN 12811-3, *Temporary works equipment — Part 3: Load Testing.*

Annexes A, B and C are informative.

According to the CEN/CENELEC Internal Regulations, the national standards organizations of the following countries are bound to implement this European Standard: Austria, Belgium, Czech Republic, Denmark, Finland, France, Germany, Greece, Hungary, Iceland, Ireland, Italy, Luxembourg, Malta, Netherlands, Norway, Portugal, Slovakia, Spain, Sweden, Switzerland and the United Kingdom.

Introduction

Based on the requirements specified, a manufacturer proposes a façade scaffold system and puts it forward for assessment and certification of conformity with the requirements of this European Standard. The structural design and assessment is carried out using the standard set of system configurations chosen by the manufacturer, taking account of the requirements of this standard.

Many of the detailed requirements are given in EN 12811-1, prEN 12811-2 and EN 12811-3 with which this European Standard should be read, EN 12810-2 gives requirements for particular methods of structural design. A façade scaffold system, which has been successfully assessed will also satisfy the corresponding requirements of EN 12811-1, prEN 12811-2 and EN 12811-3. It may be used without any further calculation within the scope of the standard set of system configurations. If the performance requirements are more onerous, or if the application is outside the standard set of system configurations, then further calculations may be needed in order to show that sufficient resistance and stiffness is provided.

It is anticipated that some systems will be able to conform to the requirements of several classes.

This conversion of HD 1000 into a European Standard is intended to create a common technical base for design. This standard has a narrower scope than HD 1000 because much has been transferred to EN 12811-1, prEN 12811-2 and EN 12811-3.

1 Scope

This European Standard specifies the performance requirements and the general requirements for structural design and assessment for prefabricated façade scaffold systems. The façade scaffolds are intended for use while connected to the façade with ties. Scaffold systems are classified by six criteria, see Table 1.

It is limited to façade scaffold systems that have standards made of steel or aluminium alloy and have other elements made of these materials or timber based materials.

It defines a standard set of system configurations under which the structural design is carried out. Other configurations may be possible with some systems, but they are outside the scope.

This standard should be read in conjunction with EN 12811-1, prEN 12811-2, EN 12811-3 and EN 12810-2 which specify certain of the requirements.

This standard does not specify requirements for protection fans. It does not give information about erection, use, dismantling or maintenance.

2 Normative references

This European Standard incorporates by dated or undated reference, provisions from other publications. These normative references are cited at the appropriate places in the text and the publications are listed hereafter. For dated references, subsequent amendments to or revisions of any of these publications apply to this European Standard only when incorporated in it by amendment or revision. For undated references the latest edition of the publication referred to applies (including amendments).

EN 39, *Loose steel tubes for tube and coupler scaffolds - Technical delivery conditions.*

EN 74, *Couplers, loose spigots and base-plates for use in working scaffolds and falsework made of steel tubes - Requirements and test procedures.*

EN 755-8, *Aluminium and aluminium alloys — Extruded rod/bar, tube and profiles — Part 8: Porthole tubes, tolerances on dimensions and form.*

EN 10204, *Metallic products — Types of inspection documents.*

EN 10219-2, *Cold formed welded structural hollow sections of non-alloy and fine grain steels — Part 2: Tolerances, dimensions and sectional properties.*

EN 12810-2:2003, *Façade scaffolds made of prefabricated elements — Part 2: Particular methods of structural design.*

EN 12811-1:2003, *Temporary works equipment — Part 1: Scaffolds — Performance requirements and general design.*

prEN 12811-2, *Temporary works equipment — Part 2: Information on materials.*

EN 12811-3:2002, *Temporary works equipment — Part 3: Load Testing.*

ENV 1999-2:1998, *Eurocode 9: Design of aluminium structures — Part 2: Structures susceptible to fatigue.*

3 Terms and definitions

For the purposes of this European Standard, the terms and definitions given in EN 12811-1 and the following apply.

3.1

Scaffold system

- a) set of interconnecting components, mostly purpose designed for the scaffold system, and
- b) the assessed standard set of system configurations and
- c) the product manual

3.2

Component

part of a scaffold system, which cannot be dismantled further e. g. a diagonal or a vertical frame

3.3

Element

integral (e. g. welded) part of a component, e. g. a transom of a vertical frame

3.4

Connection device

device which connects two or more components

3.5

Configuration

particular arrangement of connected components

3.6

System configuration

configuration of the scaffold system comprising a complete scaffold or a representative section from it

3.7

Standard set of system configurations

specified range of system configurations for the purpose of structural design and assessment

3.8

System width (SW)

maximum width class of Table 1 of EN 12811-1:2003 which can be realised between the standards

3.9

Assessment

the checking process establishing whether everything complies with the requirements specified in this standard

4 Classification

A scaffold system shall be classified in accordance with Table 1.

Table 1 — Classification of scaffold systems

Classification criterion	Classes
service load	2,3,4,5,6 in accordance with Table 3 of EN 12811-1:2003
platforms and their supports	(D) designed with (N) not designed with drop test
system width	SW06, SW09, SW12, SW15, SW18, SW21, SW24
headroom	H1 and H2 in accordance with Table 2 of EN 12811-1:2003
cladding	(B) with or (A) without cladding facilities
vertical access method	(LA) by ladder or (ST) by stair way or (LS) by both

5 Designation

The designation of a scaffold system, which is in conformity with this standard shall consist of the following parts.

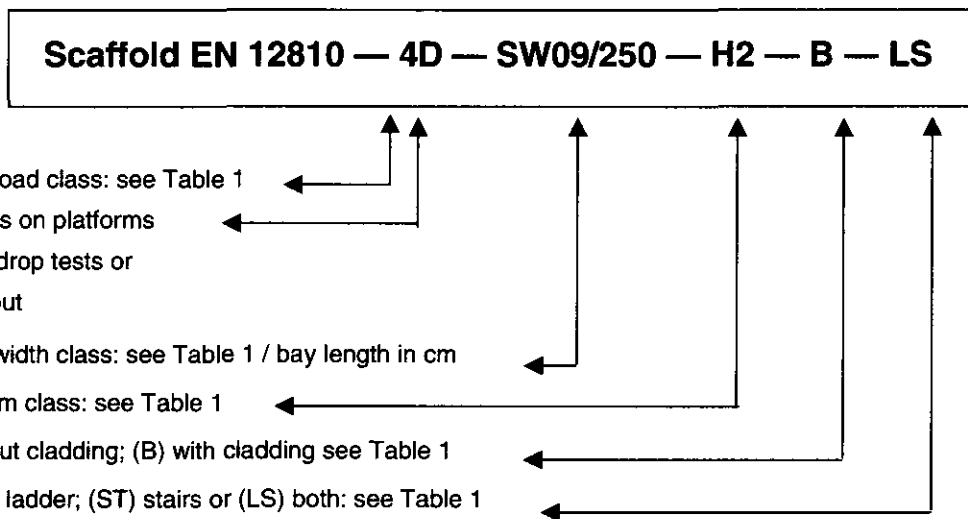

The example is of a scaffold of load class 4, system width at least 0,9 m and less than 1,2 m bay length 2,5 m, headroom between working areas and transom or tie member $\geq 1,9$ m, with cladding, with ladder and stair access.

When a scaffold system includes more than one load classes and/or dimensions a separate line of designation shall be provided for each.

6 Materials

6.1 General

Materials shall, unless otherwise stated in 6.2, be chosen in accordance with clause 4 of EN 12811-1:2003 and with prEN 12811-2. Information about the most commonly used materials is given in prEN 12811-2.

6.2 Specific material requirements

6.2.1 Types of material

The standards shall be made of steel or aluminium alloy.

6.2.2 Steel tubes (circular)

Steel tubes with an outer diameter of 48,3 mm shall be in accordance with the specification in Table 2.

NOTE For tubes with other diameters, see 4.2.1.3 of EN 12811-1:2003.

Table 2 — Combination of wall thickness and yield stress of steel tubes with an outer diameter of 48,3 mm

	Nominal wall thickness t mm	Minimum yield stress N/mm ²	Minus tolerances of the wall thickness mm
1	$2,7 \leq t < 2,9$	315	0,2
2	$t \geq 2,9$	235	in accordance with EN 10219-2

6.2.3 Aluminium tubes (circular)

Aluminium tubes with an outer diameter of 48,3 mm shall conform to the specification in Table 3.

Table 3 — Combination of nominal wall thickness and yield stress of aluminium tubes with an outer diameter of 48,3 mm

	Nominal wall thickness t mm	Minimum yield stress N/mm ²	Minus tolerances of the wall thickness mm
1	$3,2 \leq t < 3,6$	250	0,2
2	$3,6 \leq t < 4,0$	215	0,2
3	$t \geq 4,0$	195	in accordance with EN 755-8

6.3 Inspection documents

The materials used for load bearing elements shall be supplied with a test report 2.2 in accordance with EN 10204 or a specific test report 2.3. The following materials require inspection certificates 3.1B of EN 10204 at least:

- steel with a nominal yield stress higher than 235 N/mm²;
- cast iron;
- aluminium alloys;
- steel tubes for standards with a nominal wall thickness less than 2,9 mm.

The certificates for the tubes shall include the weight, the dimensions and the minus tolerance of Table 2 or Table 3 as appropriate. For materials not covered by EN 10204 comparable certificates shall be provided.

7 General requirements

7.1 Completeness of the range of components of the scaffold system

The scaffold system shall comprise a complete set of all the components necessary to erect the standard set of the system configurations, which shall be declared by the manufacturer. In detail, it means:

- a) the necessary vertical and horizontal components, see A.1;
- b) the components necessary to provide side protection at the outer side and ends of a scaffold, see A.2;
- c) the components necessary for the access method provided. See clause 4 and A.3);
- d) the following ancillary components (see A.4):
 - for all scaffold systems: bridging ledgers;- for the system width classes SW06 and SW09: platform extension components such as hop-up brackets with matching platform units;
 - if offered by the manufacturer: platform extension components for other system width classes, pedestrian frame, safety net, netting, sheeting, protection fan.

7.2 The standard set of system configurations

7.2.1 General

The standard set shall encompass system configurations for all components and anchorage patterns declared by the manufacturer in accordance with 7.1.

For all system configurations, the provisions of 7.2.2, and, for particular system configurations, the provisions of 7.2.3 shall be taken into account.

The standard set shall also include system configurations with all numbers of bays between 1 and n where n is the number of bays where the construction repeats.

7.2.2 Requirements valid for all system configurations

The system configurations shall have:

- a) height which is between 24 m and 25,5 m depending on the headroom class of the system and the length of the base jacks; this height is measured from the underside of the base plate to the surface of the topmost platform;
- b) a complete platform and side protection
 - for the system width classes SW06 and SW09, at all levels approximately 2,0 m apart;
 - for all other system width classes, at five adjacent levels approximately 2,0 m apart;
- c) adjustable base plates fully extended.

7.2.3 Requirements valid for certain system configurations

7.2.3.1 For the system width classes SW06 and SW09 and for other classes when offered by the manufacturer, platform extensions shall be able to be fitted inside at each platform level (see 7.2.2.b)) over the full length of the system configuration under consideration.

7.2.3.2 For unclad system configurations, there shall be the possibility of a zone of 3,8 m height free of all ties above and below a tied level

EN 12810-1:2003 (E)

This requirement does not apply in zones of the system configurations where there are ancillary components, e. g. bridging ledgers.

NOTE Examples for typical tying patterns are given in Figure 1. It is preferable for the tie free zone to be at least twice the normal distance between working levels. The requirement for a tie free zone is to ensure that the scaffold has sufficient strength integral in the design.

7.2.3.3 The dimensions for bridging shall fulfil the requirements of 7.3.6.1.

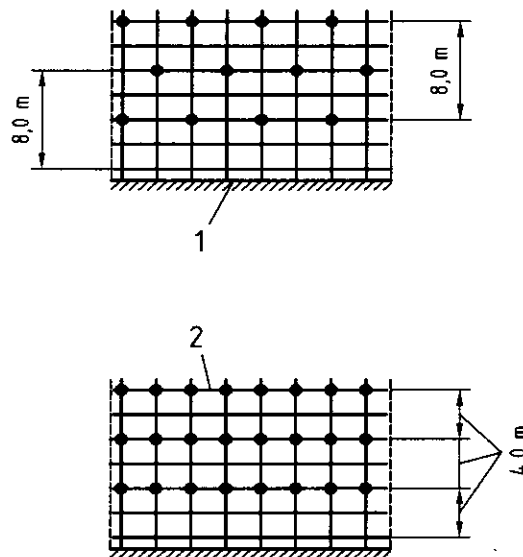

Key

- 1 Type a - typical staggered tying pattern
- 2 Type b – typical continuous horizontal tying pattern

Figure 1 — Examples of typical anchorage pattern

7.3 Further requirements

7.3.1 General

The scaffold system shall conform to clause 5 of EN 12811-1:2003 and the following additional requirements.

7.3.2 Side protection

Purpose made components shall be provided for side protection.

7.3.3 Base jacks

Base jacks shall have a minimum adjustment of 200 mm.

7.3.4 Platforms

7.3.4.1 For the versatility of platform height, the scaffold system shall include components to enable

a) the erection of adjacent pairs of standards on surfaces which differ in level by any amount up to 2,0 m;

b) the erection of a single platform at any height between 2,0 m and 2,4,0 m.

7.3.4.2 The platform surface shall be level and free from trip hazards. The scaffold system shall include appropriately dimensioned decking components in order to close any gap between them wider than 25 mm.

7.3.4.3 Where a standard separates parts of a platform, the distance between these parts shall not be more than 80 mm (see 7.3.4.2).

7.3.5 Connections

7.3.5.1 Every connection device shall be effective, easy to monitor and the components shall be easy to assemble and dismantle. The securing of connections forming part of the structure including its side protection shall make them incapable of coming undone except by direct intentional action.

7.3.5.2 Platform units shall be locked against unintentional lifting. It is preferable that the platform units are locked in position as part of the erection procedure by the addition of subsequent components. As an alternative, a fixing device may be provided which prevents their unintentional lifting up, whose satisfactory installation can be visually checked from above or below.

7.3.5.3 Adjacent platform units may be connected to reduce relative deflections, but where this is done by a separate component, that component shall not be taken into account in the assessment.

7.3.5.4 Means to connect a loose tube in accordance with EN 39 to a standard of the scaffold shall be provided.

- a) Where the standard conforms to the requirements of Table 2 or Table 3 of this standard, couplers to EN 74 may be used.
- b) Where the standard conforms to line 1 of Table 2 or lines 1 and 2 of Table 3, no account of characteristics other than slip and pull apart may be taken.
- c) For standards of any other type, a connection device shall be provided capable of transmitting at least the forces given in b).

7.3.5.5 Movable parts of a connection device such as wedges or pins shall be permanently attached to one side or the other of the connection with the exception of pins forming part of the connections of standards, which transmit tensile forces.

7.3.6 Ancillary components

7.3.6.1 The gap for bridging through the scaffold at the bottom shall have a minimum clear width of 3,5 m and a minimum clear height of 3,5 m.

7.3.6.2 Where provision is made to extend the platform laterally beyond the chosen width class, the components used shall increase the overall width by at least 260 mm.

7.3.6.3 Where provision is made for a pedestrian passage below the length of the scaffold, the space shall be in accordance with Figure 2.

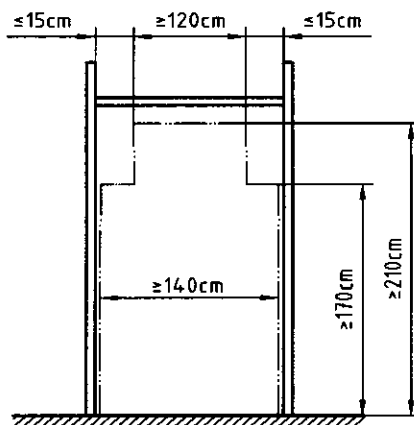

Figure 2 — Minimum clear space for pedestrian passage

8 Requirements for structural design

8.1 Actions

All system configurations shall resist the actions given in 6.2 of EN 12811-1:2003 in the combinations specified in 6.2.9. The working wind load shall be determined in accordance with 6.2.7.4.2 of EN 12811-1:2003. For the purposes of this standard the maximum wind shall be calculated using Figure 3 to obtain the velocity pressure.

NOTE 1 There is no requirement for loading from snow and ice.

NOTE 2 The velocity pressures in Figure 3 are for type assessment only. These may not be appropriate for actual use, conditions may be more onerous.

8.2 Resistances, stiffnesses

Resistances and stiffnesses of elements, components and connection devices shall be determined in accordance with prEN 12811-1 or by testing in accordance with EN 12811-3.

8.3 Application of wind loads

The maximum and the working wind shall be applied separately parallel and normal to the façade. For unclad system configurations, all components including access components shall be taken into account.

The characteristic value of the wind force, F_K , is given by equation (1):

$$F_K = c_s \times \sum_{i=1}^{i=n} (A_i \times c_f \times q_i) \quad (1)$$

where

A_i is the reference area specified in Table 4;

c_f is the aerodynamic force coefficient taken from Table 5;

c_s is the site coefficient taken from Table 6;

q_i is the design velocity pressure in accordance with Figure 3. B 9900 EEKLO

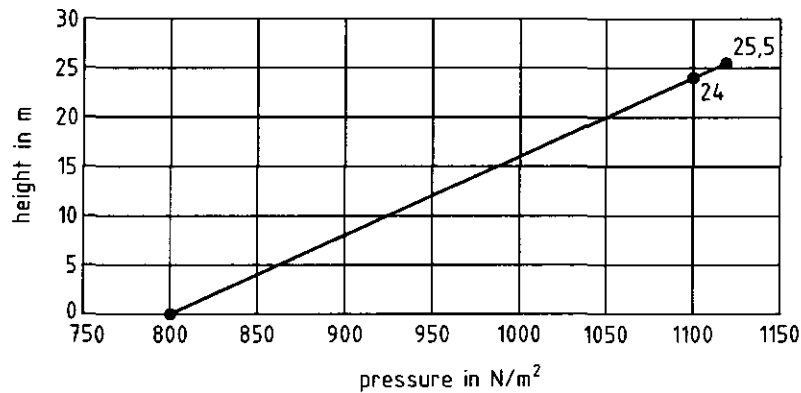

Figure 3 — Design velocity pressure

Table 4 — Reference area A_i for the wind pressure

Cladding condition of the system configuration	Reference area A_i
Unclad	area of each component projected in the wind direction
Clad	surface area of the cladding (see A.3 of EN 12811-1:2003)

Table 5 — Aerodynamic force coefficient c_f

Cladding condition of the system configuration	Force coefficient	
	Normal to the façade	Parallel to the façade
Unclad	1,3	1,3
Clad	1,3	0,1

Table 6 — Site coefficient c_s

Cladding condition of the system configuration	Site coefficient	
	Normal to the façade	Parallel to the façade
Unclad	0,75	1,0
Clad	1,0	1,0

NOTE The values for the site coefficients correspond to a façade with a solidity ratio $\varphi_B = 0,4$; see also EN 12811-1.

8.4 Drop tests for platforms

For scaffold systems of class D, platforms and their supports shall pass the drop tests in accordance with annex B of EN 12810-2:2003.

EN 12810-1:2003 (E)

8.5 Durability

8.5.1 General

In general, fatigue design does not need to be carried out for components, connection devices and configurations of scaffold systems. However, welded aluminium treads in stairways shall be checked with respect to durability either by calculation or by testing. The basis of the design shall be as follows.

The load shall be 1,5 kN and applied over an area 100 mm × 100 mm. A tread shall be checked separately at two load positions:

- a) at the centre of the tread ;
- b) with the centre of the load not more than 100 mm from the stringer;

A tread shall be capable of 300 000 loadings and unloadings.

8.5.2 Design by calculation

The durability shall be checked in accordance with ENV 1999-2 treating the load defined in 8.5.1 as an "equivalent fatigue loading" according to 1.5 of ENV 1999-2:1998.

8.5.3 Design by testing

The durability shall be checked in accordance with annex C of EN 12810-2:2003.

8.6 Vibration tests

Vibration tests in accordance to 7.4 of EN 12811-3:2002 shall be carried out for connection devices, such as wedged connections, which are susceptible to loosening under the effects of frequent load reversals. No connection shall loosen under vibration. The minimum criteria given in that document apply.

8.7 Deflections

Deflections shall not exceed those specified in 6.3 of EN 12811-1:2003, see also 7.3.5.3 of this standard.

9 Manuals

9.1 General

The manufacturer shall produce a set of instructions forming the product manual. It will be part of the basis of the structural design. The content is given in 9.2.

The manufacturer shall also produce an instruction manual for use on site, which is a subset of the product manual. The content is given in 9.3

9.2 Content of a product manual

The product manual shall include the following information subdivided as outlined in clause 8 of EN 12811-1:2003:

- a) A list of all components with descriptions from which each can be identified; for example with a drawing;
- b) instructions for the sequence of erection and dismantling the components and for the way to handle them;
- c) the layout of each system configuration of the standard set giving its class for loading and width, its overall dimensions, its anchorage pattern and how to include the ancillary components;

- d) instructions for tying under all these circumstances;
- e) a statement of limitations of use with reference to wind velocity pressure, to ice and to snow;
- f) a full specification of the items which are not purpose designed components, e. g. loose tubes and couplers;

NOTE This will enable their purchase to be arranged if they are not supplied by the manufacturer.

- g) loads imposed on the façade to which the scaffold is tied and loads on the foundation from baseplates;
- h) an indication that obviously damaged components may not be used;
- i) any instructions for storage, maintenance or repair which the manufacturer considers appropriate;
- j) structural data for components and connection devices such as resistances and stiffnesses evaluated by tests;
- k) how to obtain further information should the circumstances of the potential application be outside the standard set of system configurations, for example temporary removal of ties, or a height greater than 25,5 m;
- l) information about the restriction of the application of loads via EN 74 couplers to the standards stated in 7.3.5.4.

9.3 Content of the instruction manual

The instruction manual shall include the items a) to i) and k) of 9.2.

10 Marking

Each purpose designed component shall be marked with:

- a) A symbol or letters to identify the scaffold system and its manufacturer;
- b) the year of manufacture, using the last two digits. Alternatively a code for tracing the year of manufacture may be used.

Marking shall be so arranged that it will remain legible for the life of the component. The size of the lettering may take account of the size of the component.

11 Assessment

An assessment shall be carried out by a person or an organisation different from the original designing person and organisation.

On completion of a successful assessment a statement to that effect shall be given by the assessor. This statement shall identify the reference number of all examinations and the test report shall include:

- identification of the particular set of components examined;
- identification of the standard set of system configurations;
- structural data for components and connection devices such as resistances and stiffnesses evaluated by tests.

Annex A (informative)

Components commonly used in prefabricated scaffold systems

NOTE 1 Certain of these system components are shown on Figures B.1 and B.2.

NOTE 2 The lists are not exhaustive.

A.1 Fundamental system components

- a) fc1 standard
- b) fc2 transom
- c) fc3 vertical frame
- d) fc4 horizontal frame
- e) fc5 platform unit to form the platform of a single bay
- f) fc6 platform unit, which as a set, forms the platform of a single bay
- g) fc7 ledger
- h) fc8 diagonal for the horizontal plane
- i) fc9 diagonal for the vertical plane
- j) fc10 tie member
- k) fc11 base plate
- l) fc12 adjustable base
- m) fc13 components intended to accommodate sloping ground

A.2 System components to provide side protection

- a) pc1 principal guardrail
- b) pc2 intermediate guardrail
- c) pc3 guardrail frame
- d) pc4 multiservice guardrail unit
- e) pc5 toeboard
- f) pc6 principal end guardrail
- g) pc7 intermediate end guardrail

- h) pc8 end guardrail frame
- i) pc9 end toeboard
- j) pc10 guardrail post
- k) pc11 fencing unit
- a) A.3 Access componentscc1 ladder
- b) cc2 platform unit with access trapdoor
- c) cc3 stair flight

A.4 Ancillary components

- a) ac1 hop-up bracket
- b) ac2 platform unit for hop-up brackets
- c) ac3 protection fan
- d) ac4 bridging ledger
- e) ac5 pedestrian frame
- f) ac6 safety net
- g) ac7 netting
- h) ac8 sheeting

Annex B (informative)

Typical bracing methods

B.1 Figure B.1 shows two types of lateral bracing. Each is based on a vertical frame across the scaffold. A series set one above another will provide a stiff vertical plane.

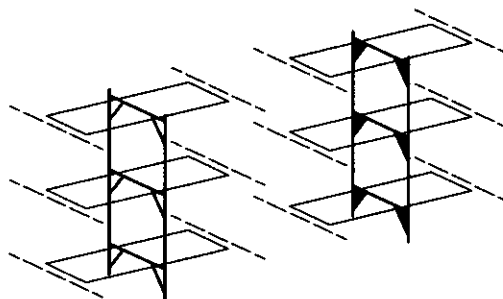
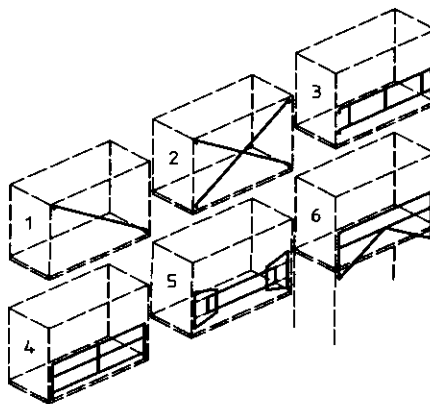

Figure B.1 — Examples of stiff vertical planes using lateral bracing

B.2 Figure B.2 shows six types of longitudinal bracing, all based on bracing the outer face of the scaffold, which provides a vertical stiff plane.



- 1 with diagonal
- 2 with St Andrew's cross
- 3 with guardrail frame (a)
- 4 with guardrail frame (b)
- 5 with guardrail frame (c)
- 6 with a multiservice guardrail unit (d)

NOTE The definition of a multiservice guardrail unit is a side protection component to be installed from a level already erected and protected, and intended to give to the level just above safety during erection and dismantling as well as during use.

Annex C
(informative)

Information about A-Deviations, selection of classes and administrative national regulations

C.1 In addition to the A-deviations as shown in annex ZB of this standard additional A-deviations are given in EN 12811-1.

C.2. Some European countries have reduced the choice of classes.

C.3 The European countries have different administrative regulations for the attestation of conformity i.e.:

- Procedure for technical approval;
- Requirements for quality control;
- Acceptance of organisations for different tasks.

**Annex ZB
(Informative)**

National A-Deviations

Germany

Facade scaffold systems as specified in this standard may only be used in Germany if the criteria stated below are satisfied. The criteria are based on the provisions for safety and health at work laid down by the Employers Liability Insurance Association BGR 165 – 174 (formerly ZH/534.0 to 534.9) the deadlines for the acknowledgement of which – 1997-02-07 and 1999-01-21 – set by the Commission in accordance with article 9, paragraph 1 of Directive 98/34/EC have passed.

- a) In deviation from 7.3.5.2 the safety mechanism against unintentional lifting of platform units shall be in accordance to EN 292
- b) Façade scaffold systems shall fulfil the protection function of service scaffolds in accordance with DIN 4420-1, published together with this European Standard.

Bibliography

HD 1000:1988, *Service and working scaffolds made of prefabricated elements — Materials, dimensions, design loads and safety requirements.*